

motogadget

m-unit

**Operating and installation guide
digital control device *m-Unit V.2***

***valid from serial no. 00005841
(see the serial sticker at the device)***

Suchen Sie die deutsche Bedienungsanleitung?

<http://motogadget.com/de/elektrik/elektronische-steuerbox-m-unit/downloads.html>



00000417

HW V2.1

SW V2.0

Manual V3.6_k

Thank you very much for purchasing a high quality product by *motogadget*.

Please read the following information and recommendations thoroughly and follow these instructions during installation and use of the instrument. No liability is assumed by *motogadget* for damage or defects resulting from negligence or failure to follow the operating and installation guide.

CAUTION !

THIS PRODUCT OPERATES ON STRONG CURRENTS. CONNECTION FAILURE MAY LEAD TO CABLE FIRE OR EXPLOSION OF VEHICLE'S BATTERY. THERE IS A RISK OF SERIOUS OR LETHAL INJURIES.

IF YOU ARE NOT A CERTIFIED MOTORCYCLE TECHNICIAN PLEASE STOP HERE AND ASK YOUR LOCAL MOTORCYCLE SHOP FOR PROFESSIONAL INSTALLATION!

SEMICONDUCTOR SWITCHES IN USE! MEASURED VOLTAGES AT TERMINALS ARE NOT SUITABLE TO DIAGNOSE A FAILURE OR DEFECT.

MOUNTING ON UNEVEN FACES WILL CRACK THE HOUSING AND CAUSE A FAILURE.

Please read the instructions below thoroughly and follow their advice when handling your device. Warranty or liability claims to *motogadget* for damages resulting from non-compliance with this manual will be null and void.

Find more product informations:

<http://motogadget.com/en/electrics/electronic-control-box-m-unit/downloads.html>

Contact:

motogadget GmbH
Köpenicker Str. 145
D - 10997 Berlin
Germany

Tel. +40 (0)30-6900410-0

www.motogadget.de
info@motogadget.de

1 Review Of Delivery

All products from *motogadget* are thoroughly checked to ensure they are completely fault free when dispatched. Please check the received goods immediately for possible transport damage. If you find any damage or other deficiencies, please contact us immediately.

In this regard we refer to our general terms of business and delivery, which are published under www.motogadget.com. Should a return of the received delivery be agreed, please note that we only take back goods in their original packaging. The instrument and its accessories must be returned within the legal period of time and without any traces of use. We do not assume any liability for returns which are insufficiently insured or packed.

2 Exclusion Of Liability

THE M-UNIT OPERATES STRONG CURRENTS. CONNECTION FAILURE MAY LEAD TO CABLE FIRE OR EXPLOSION OF VEHICLES BATTERY. THERE IS A RISK OF HEAVY OR LETHAL INJURIES. THE DEVICE AND ITS ACCESSORIES MUST BE INSTALLED BY A CERTIFIED MOTORCYCLE TECHNICIAN AND IN AN AUTHORIZED SERVICE CENTER.

IN CASE OF REVERSE POLARITY OR VOLTAGE ABOVE 24V M-UNIT CAN BE DAMAGED. THE DEVICE HAS TO BE REPLACED AND ALL WARRANTY CLAIMS BECOME INVALID.

DEVICE HOUSINGS AND ALL OTHER DELIVERED PARTS MUST NOT BE OPENED OR DISMANTLED. IN CASE OF NON-COMPLIANCE ALL WARRANTY CLAIMS BECOME INVALID. THE USE OF THE DELIVERED DEVICE AND ITS ACCESSORIES FOR RACING OR OTHER COMPETITIONS, AS WELL AS ALL USES THAT DO NOT CORRESPOND TO THE RECOMMENDED APPLICATION RENDER ALL WARRANTY CLAIMS INVALID.

MOTOGADGET ACCEPTS NO LIABILITY FOR DIRECT OR INDIRECT DAMAGE OR SUBSEQUENT DAMAGE OF ANY KIND RESULTING FROM THE USE, INSTALLATION OR CONNECTION OF THE DEVICE OR OTHER DELIVERED EQUIPMENT. THIS EXCLUSION OF LIABILITY PARTICULARLY INCLUDES DAMAGE TO PERSONS, MATERIAL LOSSES AND FINANCIAL DAMAGES. THE USE IN AREAS OF PUBLIC TRAFFIC IS UNDERTAKEN AT THE USER'S OWN RISK.

2.1 Duty Of Registration

The m-Unit does not have to be registered. The user has the responsibility that chosen settings for vehicles rear and brake light are conform to the country laws. The user also has to ensure compliance with local regulation in respect to connection and usage.

3 Technical Data And Functions

| | |
|--------------------------|--|
| length / width / depth | 101/ 61 / 28 mm |
| weight | 180 g |
| threaded fastening bores | 2 x M5, distance 84mm |
| standby current | 350µA (480µA with activated alarm function) |
| operating voltage | 3,5 - 25V, suitable for 6V and 12V power systems |
| operating temperature | - 20 - +80 °C |
| input circuits | 8 |
| output circuits | 8 |
| display | via 15 internal LED |

4 Safety Instructions

- **PRIOR ELECTRICAL CONNECTION OF THE DEVICE AND GENERALLY PRIOR TO ANY WORK AT THE VEHICLES ELECTRICAL SYSTEM BATTERY MUST BE DISCONNECTED COMPLETELY. THEREFORE KEEP THIS ORDER: DISCONNECT AT FIRST THE NEGATIVE TERMINAL AND THEN THE POSITIVE TERMINAL. FOR THE RECONNECTION ACT IN THE REVERSE ORDER.**
- **USE OF M-UNIT TO VEHICLES WITH PLUS POLE TO VEHICLE FRAME (OLDER ENGLISH MOTORCYCLES) IS NOT POSSIBLE.**
- **INSTALLATION AND ELECTRICAL CONNECTION OF THE M-UNIT HAS TO BE CARRIED OUT BY A CERTIFIED MOTORCYCLE TECHNICIAN ONLY.**
- **ALL CABLE DIAMETERS MUST BE DIMENSIONED ACORDING THE CURRENT FLOW. THE CABLE DIAMETERS MUST NOT GO BELOW THE VALUES LISTED IN CHAPTER 7.5. CURRENT FLOW OF CONNECTED LOADS MUST NOT EXEED THE VALUES LISTED IN CHAPTER 7.5**
- **THE CABLE ENDS TO M-UNIT'S CONNECTION TERMINAL MUST BE CRIMPED WITH CABLE END SLEVES. THEREFORE USE A SUITABLE CRIMPING TOOL.**
- **ALL ELECTRICAL CONNECTIONS IN THE WIRING LOOM AND AT THE CONNECTION TERMINALS HAVE TO BE CARRIED OUT IN A PROPER WAY. FAILURES AT CONNECTING JOINTS MAY CAUSE A CONTACT RESISTANCE AND MAY LEAD TO HEAT GENERATION DURING HIGH CURRENT FLOW. THERE IS A RISK OF SERIOUS OR LETHAL INJURIES.**
- **THE DEVICE WILL BECOME DAMAGED BEYOND REPAIR IF A BATTERY CABLE IS DISCONNECTED WHILE THE RUNS (LOOSE OR WORN CONTACT ETC.). PLEASE MAKE SURE THAT THE VEHICLE'S BATTERY IS CONNECTED CORRECTLY AND THAT THE CONNECTOR CABLES ARE FIXED TIGHTLY.**

5 Functions And Operation

The m-Unit is able act as central control unit in vehicle's electrical system. It provides following features:

- Entirely digital push button control unit (with optional 4- or 5-bush-button controls)
- Complete replacement of all OEM fuses. Eight independent circuits are digitally supervised. A circuit will be shut down in case of interference. After removing the interference the circuit will be switched on automatically.
- Integrated, digital, load-independent flasher relay with programmable switch off feature and adjustable position light feature
- Integrated digital brake-light modulator with programmable flashing sequence
- Integrated starter relay for solenoid switches (up to 30A current flow)
- Intelligent control and shut-down of single loads; i.e. switch headlight off during cranking to use maximum battery power.
- Control of head light's low beam and high beam (200W switched power max.) with only one push button
- Integrated digital horn relay
- Integrated alarm system (irrespective of orientation)
- Integrated hazard light feature
- Internal LED provides the status of vehicles electrical system at a glance – easy trouble shooting.
- Easy setup by a temporary push button
- Diagnostic features for the assignment of input, output, switching state of the circuit, short circuit diagnostics etc.

The device is completely moulded and resistant against water, heat, cold and vibrations. Micro-processor operated and supervised circuits guaranty highest reliability. Current flow of each circuit is measured with high accuracy. In case of a failure like a short-circuit or overload the concerning loop will be shut down in a split second. All switching activities are carried out by state of the art semiconductor switches in a fast, wear-free and almost lossless way.

Therefore no other components like relays, boxes, fuses are necessary. A complete new wiring harness can be made with minimal time; materials and effort compared to conventional solutions only a fraction of space and cables is needed. State of the art technology like pulse width modulation afford new possibilities like connecting rear and brake light together with only one cable.

The current status of each circuit is shown by an internal LED at the m-unit's topside :

| | |
|---|---|
| LED off | - input not active, output not powered |
| LED on | - input active, output powered – normal condition |
| short flashing | - output shutdown due short circuit or overload |
| one short flash each 2s (only at „lock“) | - alarm system active |

Turn Signals

Automatic shut-off can be adjust in setup menu. If this feature is activated a countdown will start once the signal is flashing. If the adjusted countdown has ended the turn signal stop flashing. The countdown will stop and set back if the brake is activated. Once the brake is released the countdown start again with full time length. If a turn signal switch is used and signals has been automatically shutting down, the switch has to set back to centre prior set the turn signal switch again to left or right. If two turn signal push button are used is additionally the lane change mode available. If the button is pressed very shortly the signals will flash only 3 times.

Hazard light

For starting the hazard light hold the push buttons for left and right turn signal for 2 seconds. If a turn light switch is used, the hazard light function can only be activated if a additional hazard light switch is activating both turn light inputs at the same time. The hazard light mode will stay active even if the main (ignition) switch is deactivated.

Light control

In order to save the vehicles battery power the head light is always switched off after key lock is switched on. The head light will be activated automatically after pressing the start button or (for kick start) after one short light switch operation.

If a push buttons is used for high/low beam control, a short push will toggle between high and low beam. Hold the button for 2s will switch off light completely. Press the button again will switch low beam on again. If a switch is used for light control it is only possible to toggle between high and low beam once the light is activated.

The m-units light circuits are suitable for standard H4 55/60W Halogen bulbs. The output connections for the lights (Light Hi Out/ Light Low Out) can withstand switched power of up to 120W. It is not possible to connect bulbs with higher power output.

The headlamp flasher feature is activated by a short tap to the push-button.

THE PARKING LIGHT FEATURE IS ACTIVATED IF HIGH BEAM IS ACTIVATED WHILE SWITCHING OFF THE MAIN (IGNITION) SWITCH. THE PARKING LIGHT FEATURE IS REALIZED BY THE EXISTING LOW BEAM AND REAR LIGHT ILLUMINANT. THERE IS NO ADDITIONAL PARKING LIGHT LAMP NECESSARY. PARKING LIGHT SHOULD NO LONGER ACTIVATED THAN 2 HOURS TO PREVENT DRAINING THE BATTERY. THEREFORE A ACTIVATED PARKING LIGHT WILL BE INDICATED BY TWO SHORT HONKS.

connection of the OEM light switch

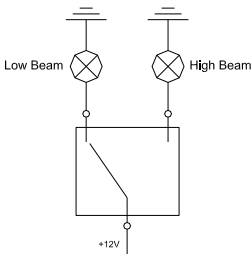

connection for m-unit

disconnect **all** switch cables and connect as shown:

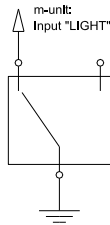

Kill switch

The running engine can be stopped in three different ways:

a) engine start button double click

Pressing the button again after engine stop will crank and start the engine in normal way.

b) Connecting a separate kill switch or push button at the "config" terminal. If a push button is used the engine is stopped if push button is shortly pressed. To release the kill function hold the button again for 2 seconds or switch ignition lock off and on again. If a kill switch is used wait for 2 seconds between switching engine off and release the kill switch.

c) When implementing controls with four push-buttons, the engine is killed by pressing the buttons for light and right turn indicator at the same simultaneously.

Alarm system

The sensitivity of the alarm system is independent of its positioning and orientation. If activated, the alarm system will flash all turn indicators when the main switch is deactivated. The vehicle's relative position and orientation will be recorded and stored and the alarm system engaged. The alarm is triggered when the orientation of the vehicle is changed on its X, Y or Z axis (e. g. when the vehicle is raised from its kickstand). Depending on the preset sensitivity, the alarm will also be triggered in case of lighter shocks or agitation resp. Depending on the chosen setup, the alarm system will trigger a pre-alarm and will only activate the alarm when the system is triggered again in a ten-second time frame.

If the vehicle is transported (e. g. by ferry, trailer or tow-truck) the alarm system can be deactivated non-recurring by pressing the horn button while switching disengaging the main switch.

If implemented within cars or sidecars, we recommend the highest sensitivity setting (option F).

6 Mechanical Installation

Mount the device on a flat surface (metal base plate) free of tension using two M5 screws.

No push or pull force should act to the device. **Area of Installation must be protected from spray water** and 30cm away from hot engine or exhaust parts. Maximum ambient temperature must not exceed +80°C or go below -20°C.

All warranties and extended warranties will be deemed forfeit in case of mechanical damage to the device.

The m-Unit is connected to vehicle ground by the two mounting screws. Therefore one of the mounting screws must connected directly to battery minus terminal. The necessary cable cross section for this connection cable is 1.5mm².

7 Electrical Connection

7.1 General

The device is working in a voltage range between 4 to 25V direct current. Use in vehicles without battery is not possible.

Make sure that the vehicle is equipped with interference suppressed spark plugs or ignition cables. The minimum distance between ignition coil or high tension cables and m-Unit must not be below 30 cm.

7.2 Safety Functions

Currents in the range from 18-40V (e. g. in case of defective controller) will trigger the activation of the horn. This prevents unnoticed battery cook-off and damage to appliances due to continued driving.

Loose cables can release currents from 40-80V. In this range, the m-unit activates all appliances to protect itself. However, the resulting protection is only short term and prolonged (several seconds) or repeated currents surges will burn out the connected appliances (e. g. high or low beam light bulbs). When the current surge can no longer be compensated, burn out occurs and the respective output will become damaged permanently. Such damage is indicated by the defective/dysfunctional high or low beam outlet. In this case, all warranty claims will become forfeit.

Reverse polarity of the battery will cause the activation of all connected appliances to protect the m-unit.

PLEASE ENSURE TIGHT BATTERY CABLE CONNECTIONS. WHILE THE ENGINE IS RUNNING, LOOSE CONTACTS CAN CREATE STRONG CURRENT SURGES ABLE TO DAMAGE APPLIANCES AND M-UNIT BEYOND REPAIR.

7.3 Fuses

While the m-unit itself does not need a fuse, the implementation of a vehicle main fuse is mandatory since the voltage regulator (connected to the battery via the main fuse) might malfunction and create a short circuit.

If cables with a lesser diameter than indicated in Chapter 7.4 are connected (e. g. motogadget instruments or the m-lock), they have to be protected by the included fusible links.

7.4 Cable Routing Recommendations

Cables used in vehicles must be suitable for this application. We recommend our cable kit (order # 4002031). Cable insulation must have a adequate thickness and insulation material must have a resistance against fuel, oil, cold and heat. Please use only cables which are certified for use in vehicles. Not fused wires which lead from battery positive terminal to starter motor or to m-Unit must have the shortest length possible. It is very important to protect the insulation of these cables against damage by wearing. At contact points between cable and vehicle parts additional insulation protection is necessary. Before routing cables look for suitable cable paths. The cables should be as far away as possible from hot parts of the engine. Look for a suitable place for the respective cables to meet with their plugs and for the plugs to be connected with one another. This is usually in the headlight housing, somewhere below the gas tank or in the cockpit. Make sure you take note of the required lengths of cables before cutting them for best fit. It is important here to consider the full lock of the handlebars as well as the front and rear wheel travel. All cables should be routed free of kinks and should not be subject to any tension.

In addition, the cables have to be properly isolated, especially in places where mechanical wear can take place. We recommend solder joints. For fastening the cables we recommend cable ties of synthetic material.

To prevent corrosion from the m-unit terminals you **must** apply terminal grease to the screws and into the cable inlets.

For preparing a cable for connection to a m-unit terminal; remove 15mm of cable insulation and crimp a cable end sleeve over the free cable end. Cut sleeve with inserted cable to approx. 6mm, put it into the dedicated cable inlet and tighten the terminal screw.

7.5 Wire Cross Sections

Wire diameters used in a circuit are dependant on the current flow that particular circuit. Following plan shows the minimum wire cross sections used in the single circuits of m-Unit. The installed wire cross sections must not go below the shown values.

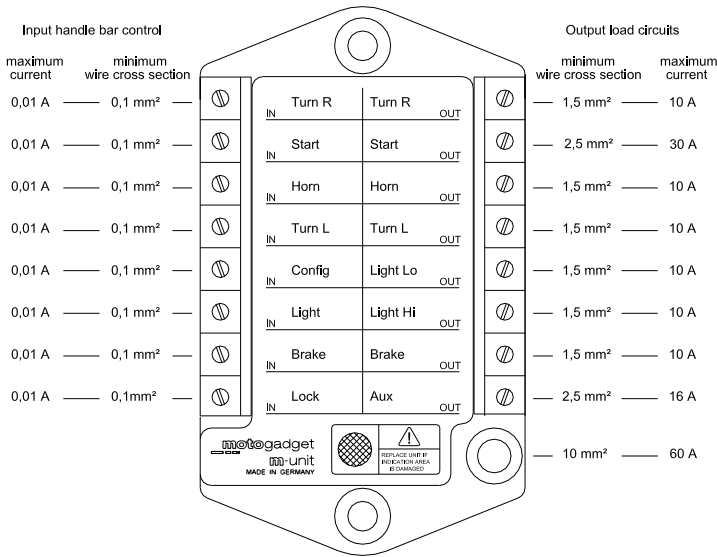

7.6 Connecting Battery's Positive Terminal

Cable connection has to be carried out as shown in the drawing at the right side.

The minimum wire cross section must no go below 10mm².

The cable end has to be supplied with an eyelet and will be mounted with a M5 screw to the m-Unit.

The maximum torque applied to the M5 fastening screws must not exceed 4 Nm. Screw adhesive medium strength **must** be applied to the screw prior installation.

MAKE SURE THE EYELET IS INSULATED IN A PROPER WAY AND CANNOT GET IN CONTACT TO OTHER PARTS CONNECTED TO VEHICLE GROUND.

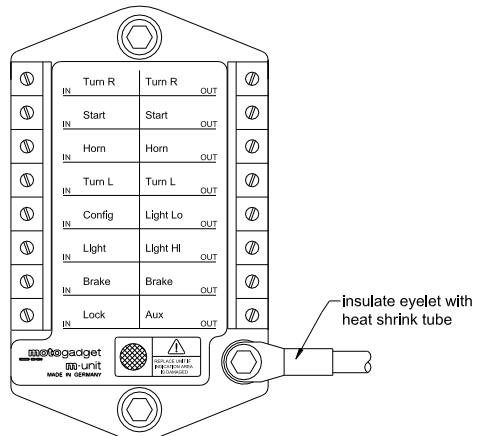

7.7 Handle Bar Controls

Three different types of handle bar controls are compatible with m-Unit. The particular type which will be used with m-unit must set in the setup menu.

Configuration A) – 5-push button controls

- | | | | |
|---|----------------------|---|-------------|
| - | turn lights left | - | push button |
| - | turn lights right | - | push button |
| - | low beam / high beam | - | push button |
| - | start | - | push button |
| - | horn | - | push button |

Configuration B) – Harley Davidson and BMW controls

- | | | | |
|---|----------------------|---|-------------|
| - | turn lights left | - | push button |
| - | turn light right | - | push button |
| - | low beam / high beam | - | switch |
| - | start | - | push button |
| - | horn | - | push button |

Configuration C) – most Japanese and European motorcycles

- | | | | |
|---|--------------------------|---|--------------|
| - | turn lights left / right | - | 3 way switch |
| - | low beam / high beam | - | switch |
| - | start | - | push button |
| - | horn | - | push button |

configuration D) – new Ducati models

- | | | | |
|---|--------------------------|---|--------------|
| - | turn lights left / right | - | 3 way switch |
| - | low beam / high beam | - | push button |
| - | start | - | push button |
| - | horn | - | push button |

configuration E) – 4-push-button controls

- | | | | |
|---|----------------------|---|-----------------------------------|
| - | turn lights left | - | push button |
| - | turn lights right | - | push button |
| - | low beam / high beam | - | push button |
| - | horn | - | push button |
| - | start | = | left turn + light simultaneously |
| - | kill switch | = | right turn + light simultaneously |

In case of using the OEM handle bar controls together with m-Unit; head light flashing push button is not applicable. There is also no possibility to switch the parking light by the m-Unit.

Additional safety switches like side stand switch have to be connected as shown in chapter 7.9.

7.8 Connecting Load Circuits

The m-Unit provides 8 independent circuits which are permanently supervised. At all connected loads were the positive terminal switched, that means, from m-Unit's output terminal lead one cable to the load which is connected to vehicles earth. At the particular output only the intended load must be connected. The connection scheme is shown on next page. If control lamps will be used; these have to be connected in parallel to the load as shown in chapter 7.9

Simplified vehicle circuit diagramm with m-Button (optional accessory)

The circuit diagram below shows a simplified vehicle wiring loom with use of the m-button. Therefore 6 wires do not apply, because only one cable is needed to connect handle bar controls with m-unit.

THE M-BUTTON MUST LOCATED INSIDE A METAL HANDLEBAR TUBE.

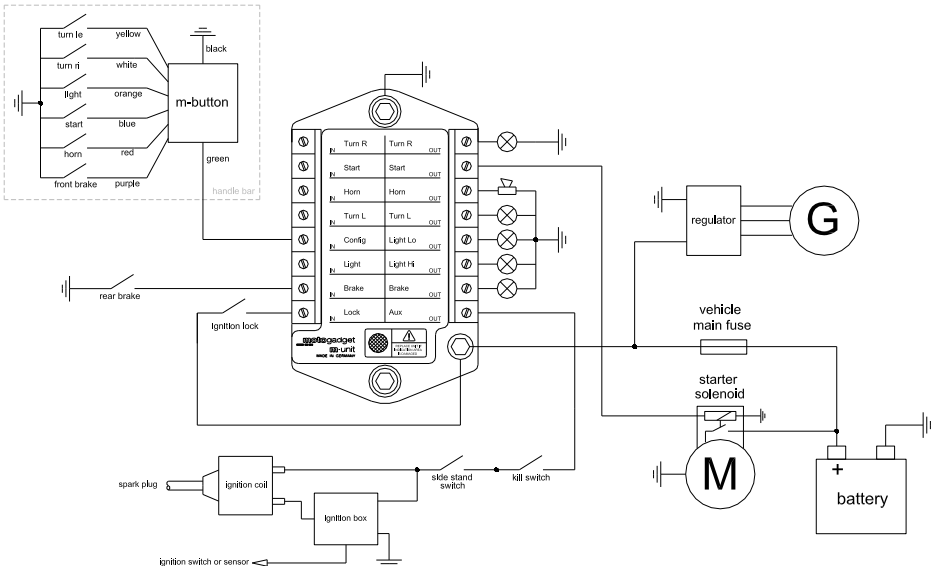

7.8.1 Important Notes

M-Unit's Starter Motor Output „start“

Starter motors which coming with solenoid and a solenoid current consumption of maximum 30A (like Valeo, Bosch, Harley Davidson) can be connected directly to the m-Unit's „start“ output. In this case a cable diameter of 2,5mm² has to be applied. All starter motors with external relay (like Japanese Motorcycles) have to be still powered via the OEM relay. In this case m-Unit's output „start“ is connected with the relay which switches the actual cranking current (>100A). Some Motorcycles have an additional relay to switch the start relay; this second relay is not needed.

One – Wire – Taillight

In conventional way is the output „brake“ is connected to the brake light and the output „AUX“ connected to the rear light. If you like to route only one wire for tail light and brake light together; you have to adjust the right setting in the setup menu (chapter 8). Furthermore the rear light and brake light will be connected in parallel and one terminal to m-Unit output “brake” and the other terminal to earth. Observe polarity if an LED light is applied.

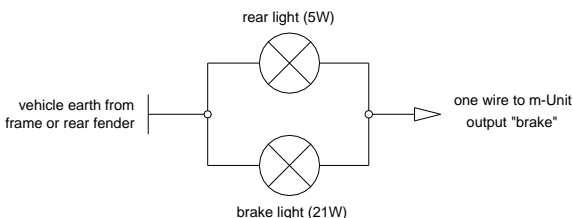

Auxiliary Output

Output AUX (auxiliary) powers the ignition system. **The ignition system must be connected only with this output.** All further loads which are not listed in the drawing below (like heat grips, radio) will be also powered only by this output circuit. If more than two cables should be connected to AUX outlet all necessary cables have to be combined with a external terminal.

Ignition Lock

If m-Lock from motogadget will be applied instead of a conventional ignition lock the m-lock switching output (brown cable) can be connected directly to the m-Unit input „lock“. The delivered m-Lock relay is not applicable.

Remarks:

Older Japanese motorcycles have ignition locks with integrated resistors (simplified theft security). If the ignition lock will be removed the ignition system is only functional if a certain wire which was connected ignition box with key lock is connected with a resistor to ground or plus. The necessary resistor can be measured at the ignition lock and purchased in a electronic supply shop.

If the vehicle comes with a immobilizer system this system is deactivated by a transponder inside the ignition key. In this case the ignition lock can not be removed.

7.9 Connecting Indicator Lights

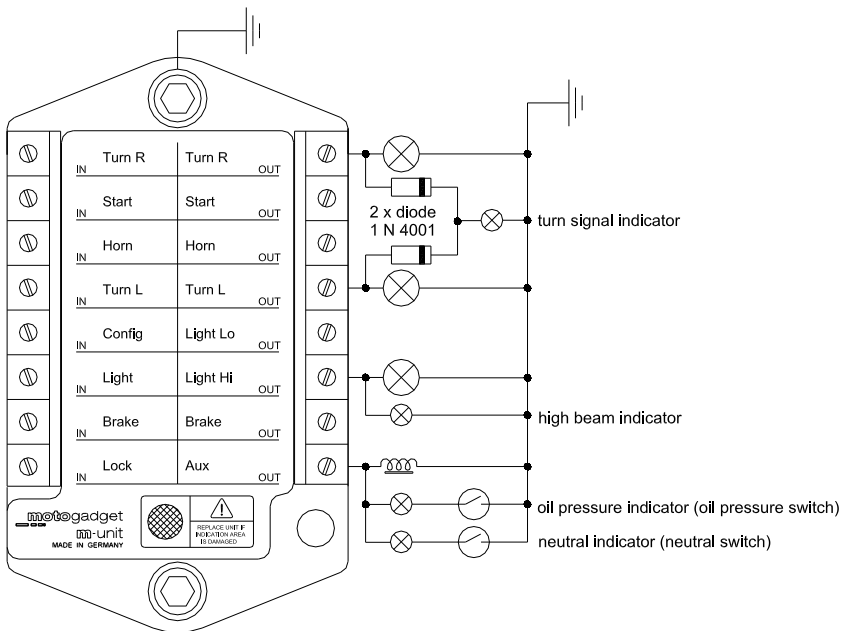

8 Setup

8.1 Layout

Device setup is structured in 7 menus (1-7) with particular options (A-F) as follows:

Menu 1 – Brake light configuration

- A) standard (continuous light) > default setting
- B) fade in and fade out
- C) flashing
- D) 8 times flashing and continuous light
- E) 2 times flashing; 1s continuous light and start again
- F) 3s continuous light and flashing

Menu 2 – Rear light configuration

- A) standard (brake light connected to „brake“ and rear light to „AUX“) > default setting
- B) one wire rear light / brake light for LED
- C) one wire rear light / brake light for light bulbs

Menu 3 – Turn lights configuration

- A) standard (no automatic shut down) > default setting
- B) shut down after 10s
- C) shut down after 20s
- D) shut down after 30s
- E) shut down after 40s
- F) shut down after 50s

Menu 4 – Alarm configuration

- A) alarm deactivated > default setting
- B) medium sensitivity, pre-alarm
- C) high sensitivity, pre-alarm
- D) low sensitivity, no pre-alarm
- E) medium sensitivity, no pre-alarm
- F) high sensitivity, no pre-alarm

Menu 5 – Handle bar control configuration (see chapter 7.6)

- A) configuration A (5 push button control) > default setting
- B) configuration B (HD and BMW)
- C) configuration C (Japanese and European motorcycles)
- D) configuration D (new Ducati models)
- E) configuration E (4 push button mode)

Menu 6 – Turn lights as position lights

- A) function deactivate > default setting
- B) brightness 10%
- C) brightness 20%
- D) brightness 30%
- E) brightness 40%
- F) brightness 50%

Menu 7 – m-Wave (smooth turn signal)

- A) function deactivate > default setting
- B) function activated

8.2 Navigation Through Setup Menu

All LED at input side represent menu 1 - 7. All LED at the output side represent option A - F.

Flashing LED shows the actual chosen menu or option.

A short push button operation (less than 1 second) changes to the next menu or option. A long push button operation (2s) change between menu and options. The following drawing shows all menus and option at a glance.

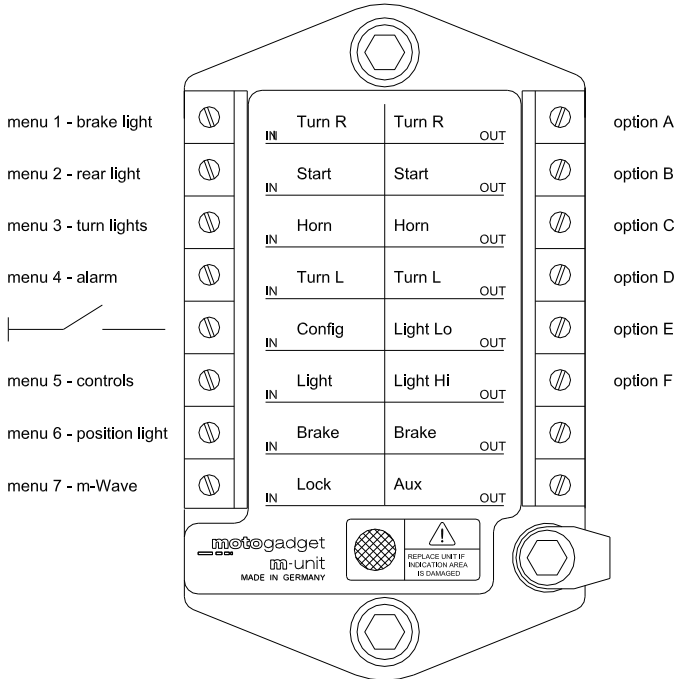

8.3 Starting The Setup

- **disconnect all wires** from input "Config" (i.e. m.button, or kill switch)
- connect a 1m long wire to the input "Config", remove insulation from the open wire end
- Switch vehicle power on and instantly if the running light appears touch the open wire end with battery minus pole for 2 seconds.
- now remove the wire from battery minus pole - if the LED at "Turn R in" is blinking, the setup has started

Right timing is important! Setup will be started only if input "Config" is connected to earth WHILE the running light.

8.4 Exit From Setup

Hold the push button until the device changes back to normal operation mode.

8.5 Example

The following example is demonstrating the operation in setup mode. Alarm is deactivated and is recommended to be set to "sensitive". Here is shown how it will be activated with a delay time of 30s. Starting the setup as described in chapter 8.3

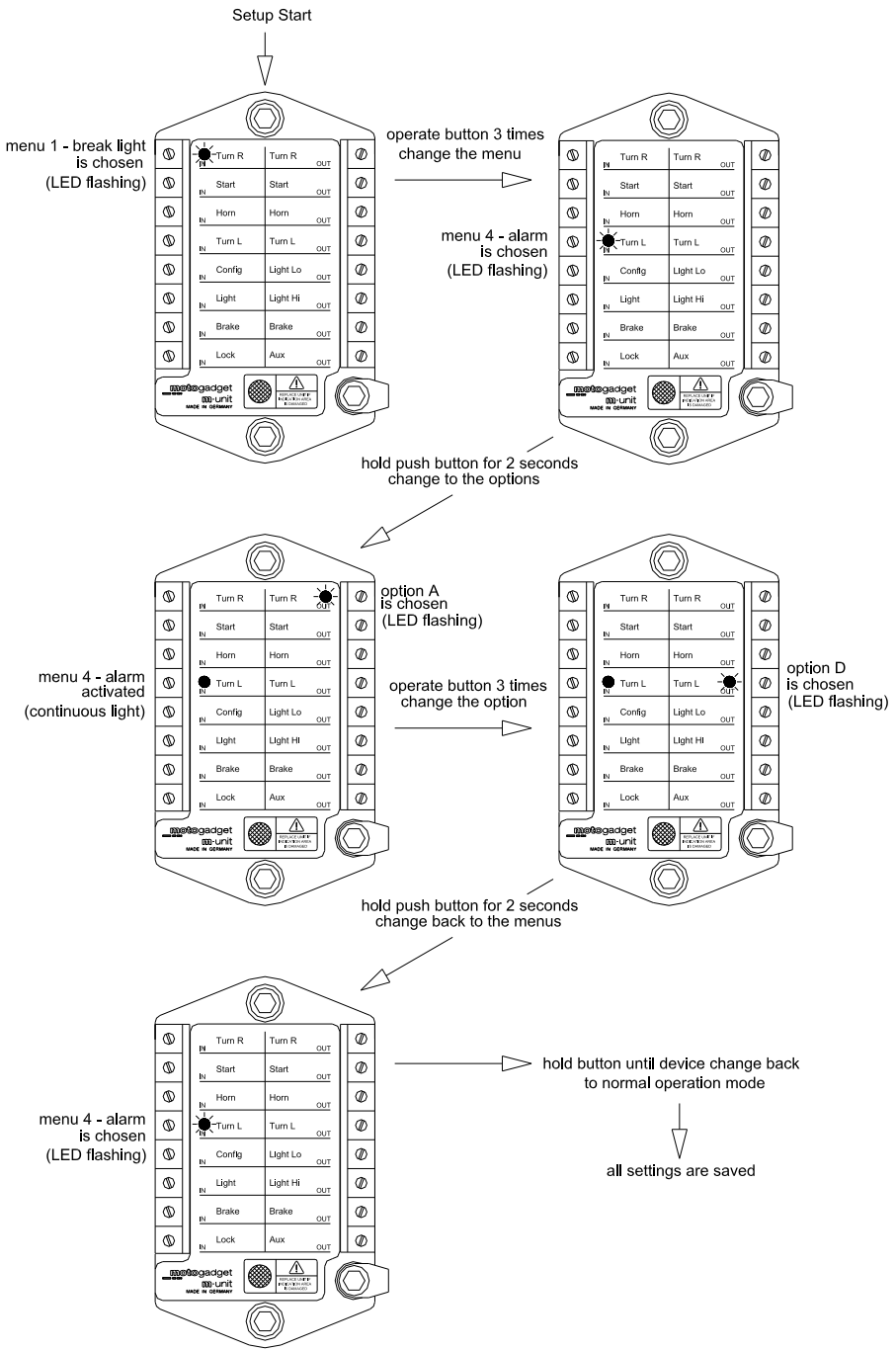

9 Trouble shooting

9.1 After Installation and during Initial Operation

- Make sure the battery voltage is minimum 12,6V.
- Do not use a battery charger to test the device.
- Check for a perfect electrical connection between both mounting bolts at m-Unit base and battery negative terminal.
- Check all cables, for correct polarities and short-circuits.
- Voltage checks at input and output connectors is not possible, since they are always energised to some extent. This minor voltage is no indicator for proper or improper operation of the in- or output. Operational testing has to be conducted with an appliance in place (e. g. light bulb).
- Check all cables, for adequate connection and contact at connection joints.
- Check if the safety circuit indicator area on the top side is damaged; if yes the unit has to be replaced

| Failure | Reason | Relief |
|--|--|--|
| Alarm is not working | alarm is not activated | adjust setup menu 4 to option B-E |
| m-Unit is re starting (running light) if starter is activated | battery breaks down during attempted start | Check connector cables, load or replace battery |
| start output is shut off when start is activated (blinking LED) | bad electrical connection between ground and m-Unit connection bolts | install a separate cable from battery minus to one of the connection bolts |
| | current flow through starter or OEM starter relay is to high | use a separate starter relay |
| | bad electrical connection from battery to vehicle power system | make a suitable connection and use proper ground cable |
| load circuit is shut off (blinking LED) | bad electrical connection between ground and m-Unit connection bolts | install a separate cable from battery minus to one of the connection bolts |
| | bad electrical connection at m-Units terminal | use core cable ends, consider cable width, tighten terminal screw |
| | current flow is to high | load must within the specifications (light bulbs max. 2 x 60W) |
| | short circuit | remove the sort circuit |
| All turn signals are glowing | position light feature is activated | adjust setup menu 6 to option A |

9.2 Return And Complains

If you like to return a defective instrument for repair or change please observes following issues:

- Make sure again there is no connection failure. In doubt use a different voltage source to recheck.
- print and fill the repair return form (refer link below) and attach it http://motogadget.com/media/downloads/support/form_return_repair.pdf
- Not prepaid shipments will be rejected.
- The Shipment to motogadget is carried out by your own risk - you are responsible for a sufficient insurance.
- Make sure the package is adequate.
- If you are located outside the EU, you have to declare "repair item" and value 1 Euro in shipment custom declaration.
- Service provided for all not instrument related malfunctions (i.e. defective connection joints, wrong parameter settings and other vehicle related problems) will be charged with 20 EUR.
- Software updates for extending functionality will be charged with 25 EUR.

The *motogadget* team wishes you pleasant and safe riding, and lots of fun with your new *m-Unit*.